

LEGEND  = KEY PRODUCT CHARACTERISTICS

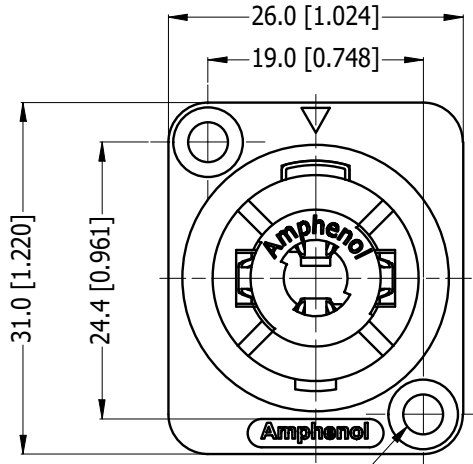

| REVISION HISTORY |                                  |    |          |      |
|------------------|----------------------------------|----|----------|------|
| REV              | DESCRIPTION                      | BY | DATE     | ECN  |
| 0                | FIRST ISSUE                      | HH | 14-02-11 | 8990 |
| 1                | ADD Amphenol LOGO TO CENTRE FACE | MH | 10-10-22 | 9707 |



REFER TO TABLE OF PART No. FOR MOUNTING HOLE DETAIL

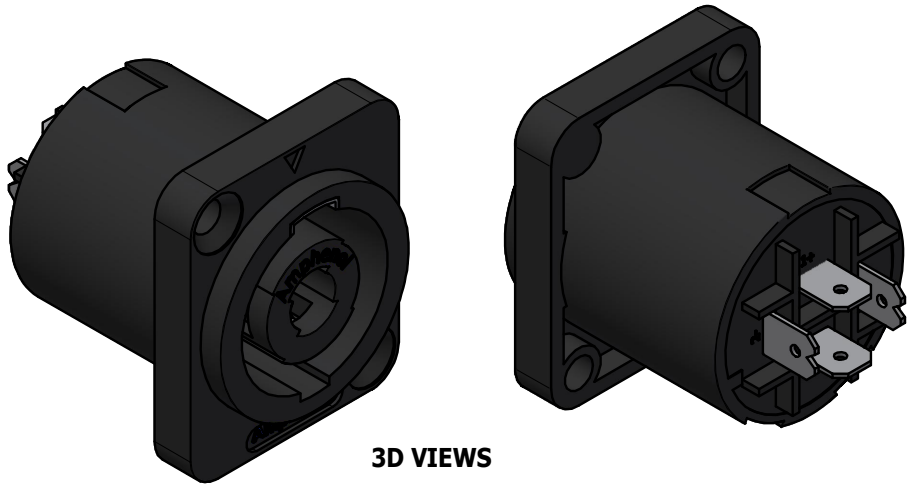
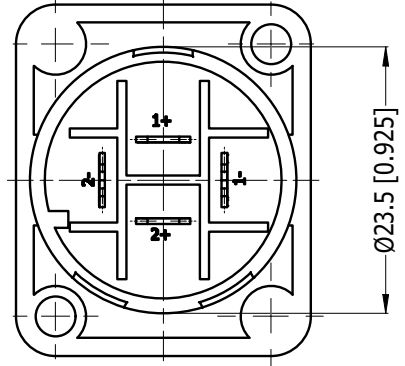
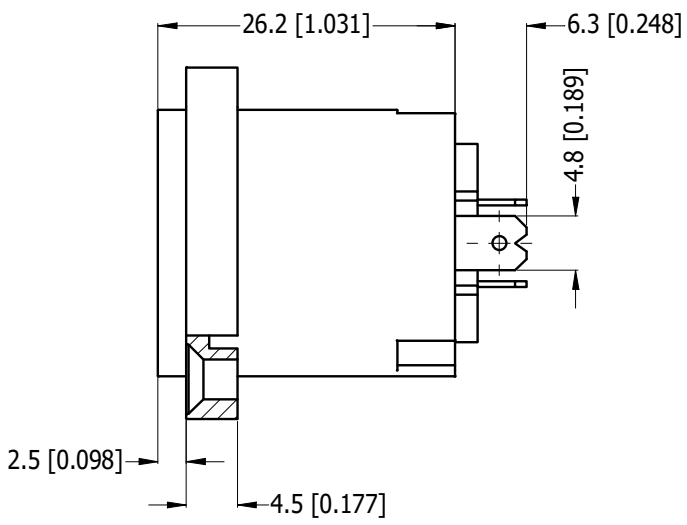

3D VIEWS

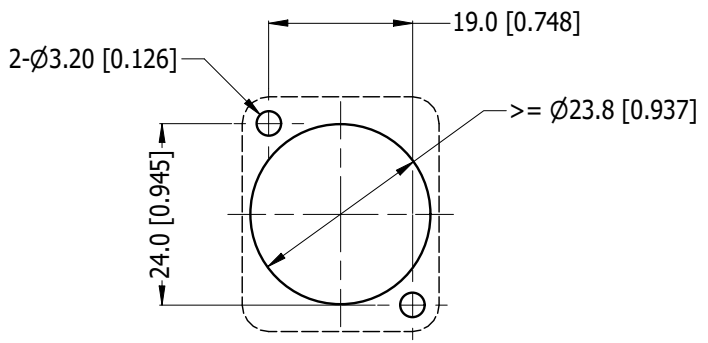

PANEL CUTOUT (SCALE 1 : 1)

| PART NUMBER TABLE |                         |              |
|-------------------|-------------------------|--------------|
| PART NUMBER       | MOUNTING HOLES (mm)     | SHELL COLOUR |
| SP-4-MD           | Ø3.5 TRHU HOLES         | BLACK        |
| SP-4-MD-1         | Ø3.5 TRHU HOLES         | BROWN        |
| SP-4-MD-8         | Ø3.5 TRHU HOLES         | GREY         |
| SP-4-MDT          | Ø2.3 SELF TAPPING HOLES | BLACK        |
| SP-4-MDT-1        | Ø2.3 SELF TAPPING HOLES | BROWN        |
| SP-4-MDT-8        | Ø2.3 SELF TAPPING HOLES | GREY         |

| UNLESS OTHERWISE SPECIFIED TOLERANCE TO BE |             |
|--|-------------|
| LINEAR                                     | ANGULAR     |
| X ± 0.5                                    | X' ± 1      |
| X.X ± 0.1                                  | X.X' ± 30'  |
| X.XX ± 0.05                                | X.XX" ± 15' |

BREAK ALL SHARP EDGES AND REMOVE ALL BURRS

DO NOT SCALE

THIS DOCUMENT IS THE PROPERTY OF AMPHENOL AUSTRALIA PTY. LTD. NO PART THEREOF MAY BE REPRODUCED AND USED WITHOUT THE PRIOR WRITTEN CONSENT OF THE OWNER

MATERIAL: **REFER TO COMPONENTS**

DRN: HH DATE: 10-02-11  
 CKD: MH DATE: 10-10-22  
 APP'D: PM DATE: 10-10-22

FINISH:

SCALE: **3:2** SIZE: **A4**

**Amphenol** Amphenol Australia Pty.Ltd, 22 Industry Blvd, Carrum Downs, VIC 3201

TITLE: **SP SERIES CONNECTOR LOUDSPEAKER 4 POLE FLAT TABS**

PART No. **REFER TO TABLE**

DRAWING No. **55010738-000-2** SHEET **2/2**

CAD FILE: 55010738000110

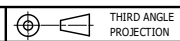

THIRD ANGLE PROJECTION

DIMENSIONS IN MILLIMETRES